

Arrangement 9 axial fan

Models TAF - WAF - HTF - WAF/HTF

INSTALLATION - OPERATION - MAINTENANCE

CF-15-IOM-24 ISSUED 5/2024

READ AND UNDERSTAND THIS MANUAL PRIOR TO OPERATING OR SERVICING THIS PRODUCT



Serial Number _____

overview

Note *Read entire manual, including “Initial Unit Startup” before attempting to install and operate this equipment.*

Specifications

Serial Number _____ Mfg Date _____

Note: The serial number above is a required reference for ant assistance. It is stamped on the lower nameplate.

Fan Specifications

Model _____ Propeller Number _____

Fan Performance Data

CFM _____ SP _____ Motor bhp _____

Density _____ Altitude ft _____ Airstream Temperature _____ °F

Fan RPM _____ Maximum Safe Fan RPM _____ **Do Not Exceed this RPM**

Motor Data: (This section is completed only if the motor was supplied by Cincinnati Fan)

hp _____ RPM _____ Voltage _____ Phase _____

Hz _____ Frame Size _____ Enclosure _____ Efficiency _____

If Motor is EXP, Class(es) and Group(s) are _____

Manufacturer's Model Number _____ CFV Part Number _____

Drive Data:

Fan Sheave _____ Motor Sheave _____ Belts _____

No. of Grooves _____ Fixed Speed Size _____ Adjustable Speed _____

Note *All Cincinnati Fan products are packaged to minimize any damage during shipment. The freight carrier is responsible for delivering all items in their original condition as received from Cincinnati Fan. The individual receiving this equipment is responsible for inspecting this unit for any obvious or concealed damage. If any damage is found, it should be noted on the bill of lading before the freight is accepted and the receiver must file a claim with the freight carrier.*

Long Term Storage Notice

If this fan will not be installed and put into operation within 30 days, refer to the **Long Term Storage** Instructions on page 20. Failure to follow all applicable long term storage instructions, will void your warranty. This fan should be stored indoors in a clean, dry location.

contents

General.....	4
- Unpacking and Handling	4
- Safety Instructions and Accessories	4
Installation.....	6
- Vibration.....	6
- Mounting Methods	7
- Safety Guards.....	7
- Dampers and Shutters	7
- Set Screw and Taper-lock Bushing Torque.....	7
- Fan Bearings	8
- V-Belt Drives.....	8
- V-Belt Installation.....	9
Electrical.....	12
- Disconnect Switches.....	12
- Motor	12
- Maximum Speed and Speed Controllers.....	14
Initial Unit Startup	15
- Pre-Startup and Post-Startup Checks	15
- Vibration.....	16
Routine Inspection and Maintenance.....	17
- Hardware.....	17
- Motor and Fan Bearing Lubrication	17
- Propeller Balance.....	19
- Vibration.....	19
- Fan Shaft or Bearing Replacement.....	20
- Dampers and Shutters	23
- Safety Equipment and Accessories	24
Ordering Replacement Parts	24
Troubleshooting.....	25
Long Term Storage	26
Warranty, Limits of Liability, Responsibility and Returns.....	28
Parts Drawing	30

Note

The following defined terms are used throughout this manual to bring attention to the presence of hazards of various risk levels, or to important information concerning the life of the product.

Warning

Indicates presence of a hazard which can cause severe personal injury, death or substantial property damage if ignored.

Caution

Indicates presence of a hazard which will or can cause personal injury or property damage if ignored.

Note

Indicates special instructions on installation, operation or maintenance which are important but not related to personal injury hazards.

general

Receiving

Unpacking

Be careful not to damage or deform any parts of the fan when removing it from the packaging container. All the packaging material should be kept in the event the fan needs to be returned.

Handling

Handling the fan should be performed by trained personnel and be consistent with all safe handling practices. Verify that all lifting equipment is in good operating condition and has the proper lifting capacity. The fan should be lifted using well-padded chains, cables or lifting straps with spreader bars. **Never** lift the fan by an inlet or discharge flange, fan or motor shaft, motor eye bolt, or any other part of the fan assembly that could cause distortion of the fan assembly.

Safety Instructions and Accessories

Safety Instructions:

All installers, operators and maintenance personnel should read AMCA Publication 410-96, *Recommended Safety Practices for Users and Installers of Industrial and Commercial Fans*. This manual is included with the fan.

Sound

Some fans can generate sound that could be hazardous to personnel. It is the responsibility of the user to measure the sound levels of the fan and/or system, determine the degree of personnel exposure, and comply with all applicable safety laws and requirements to protect personnel from excessive noise.

Air Pressure and Suction

In addition to the normal dangers of rotating machinery, the fan can present additional hazards from the suction or pressure created at the fan inlet or discharge.

Suction at the fan inlet can draw materials into the fan where they become high velocity projectiles at the discharge and cause severe personal injury or death.

It can also be extremely dangerous to persons in close proximity to the inlet or discharge as the forces involved can overcome the strength of most individuals.

Never operate a fan with a non-ducted inlet and/or discharge. If the fan inlet and/or discharge is non-ducted, it is the users responsibility to install an inlet and/or discharge guard.

Warning

Caution

general

Temperature

⚠ Caution

Many fans, fan components and all motors operate at temperatures that could burn someone if they come in contact with them. If this potential hazard could exist in your installation, steps must be taken by the user to protect anyone from coming in contact with this equipment.

The maximum airstream temperature for this fan is:

Model	Maximum Airstream Temperature
TAF - WAF	200°F (93°C)
HTF - WAF/HTF	375°F (191°C)

Spark Resistance: Per AMCA Standard 99-0401-86 and ISO 13499

⚠ Warning

No guarantee of any level of spark resistance is implied by spark resistant construction. It has been demonstrated that aluminum impellers rubbing on rusty steel can cause high intensity sparks. Air stream material and debris or other system factors can also cause sparks.

Safety Guards

All moving parts must be guarded to protect personnel. Safety requirements can vary, so the number and types of guards required to meet company, local, state and OSHA regulations must be determined and specified by the actual user or operator of the equipment.

⚠ Caution

Never start any fan without having all required safety guards properly installed. All fans should be checked on a regular schedule, for missing or damaged guards. If any required guards are found to be missing or defective, the power to the fan should be immediately turned off and locked out in accordance with OSHA regulations. Power to the fan should Not be turned back on until the required guards have been repaired or replaced.

This fan can become dangerous due to a potential “windmill” effect, even though all electrical power has been turned off or disconnected. The fan propeller should be carefully secured to prevent any rotational turning before working on any parts of the fan/motor assembly that could move.

Access or Inspection Doors

⚠ Caution

Never open any access or inspection doors while the fan is operating. Serious injury or death could result from the effects of air pressure, air suction or material that is being conveyed. Disconnect or lock out power to the fan and let the fan propeller come to a complete stop before opening any type of access or inspection door.

installation

Installation

Vibration

Before any mounting method is selected, the user should be aware of the effects vibration will have on the fan, motor and other parts. Improper fan installation can cause excessive vibration causing premature prop and/or bearing failure, that is not covered under warranty. Vibration eliminator pads or springs should be properly installed to prevent any fan vibration from transmitting to the foundation or support structure.

Shut the fan down immediately if there is any sudden increase in vibration.

Duct Work Mounting Methods

Any component of a building structure that will be supporting the fan and any duct work must have the weight load capacity and be rigid enough to support the weight of the fan without bending, bowing or flexing during operation. If not, severe vibration can occur that could lead to fan and/or structural failure. Consult an architectural or structural engineer for assistance.

Tube axial fans are designed to be mounted in duct work of the same diameter as the fan. The flange rings are pre-punched and should be bolted to duct flanges having the same dimensions. Companion rings are available as an option, to make the connection process easier. These fans can be mounted with the fan and motor shaft in a horizontal or vertical up-blast (motor shaft down) configuration.

If this fan will be mounted in a vertical down-blast configuration, with the motor shaft up, the propeller Must be secured to the fan shaft with a pin or locking collar. If there is no pin or locking collar to additionally secure the propeller to the fan shaft, Do Not use the fan without adding this feature. Not providing this feature could lead to property damage, injury or death.

The use of flexible connectors on the inlet and outlet of the fan will make it possible to mount this fan in a duct system and isolate any fan/motor vibration from the duct work. If flexible connectors will be used, the fan should be equipped with horizontal or vertical support clips. Threaded rods should be used to connect the support clips to the building structure. Each rod should be strong enough to support two times the weight of the entire fan/motor assembly. Spring hangers would be needed on the rods to isolate any fan vibration from the building.

⚠ Caution

⚠ Warning

installation

Machinery Mounting Methods

If this fan will be mounted on machinery, the surface it will be mounted to must be strong and rigid enough to support the weight of the entire fan without flexing, bowing, bending or oil-canning and thus causing vibration. Companion rings are available that will match the flanges on this fan. To minimize any leakage, it is recommended that some type of caulking be used between the fan flange and the machine.

Safety Guards

Cincinnati Fan offers guards, as options, to keep your fan in compliance with OSHA safety regulations. These include inlet or discharge guards and belt guards. It is the responsibility of the user to make sure this fan meets all local, state and OSHA safety regulations. If you have a specific guard requirement not covered by OSHA, please contact the local Cincinnati Fan sales office for assistance.

Dampers and Shutters (airflow control devices)

If the fan is supplied with any type of air flow control device, it should be closed before initial startup of the fan to minimize overloading of the motor. Any airflow control device, with bearings, should be maintained in accordance with the manufacturers instructions. Any air flow control device, with an automatic control mechanism, should be adjusted per the manufacturers recommendations.

Set Screw and Taper-Lock Bushing Torque Values

All propeller set screws are tightened to the proper torque prior to shipment. Some propellers may have taper-lock hubs and split, taper-lock bushings to secure the propeller to the fan shaft.

Note

Check all set screw or taper-lock bushing torques. Forces encountered during shipment, handling, rigging and temperature can affect factory settings. For correct torque values, see Tables 1 and 2.

Diameter and Number of Threads/Inch	Hex Wrench Size (across flats)	Required Torque in·lbf
1/4-20	1/8"	65
5/16-18	5/32"	165
3/8-16	3/16"	228
7/16-14	7/32"	348
1/2-13	1/4"	504
5/8-11	5/16"	1104



installation

Table 2

Taper-Lock Busing Size	Required Torque in·lbf
H	95
B	192
P	192
Q	350
R	350

⚠ Caution

Set screws should never be used more than once. If the set screws are loosened, they must be replaced. Use only knurled, cup-point, set screws with a nylon locking patch.

Fan Bearings

If the fan bearings have set screws to lock the bearings onto the fan shaft, the set screws should be tightened to the same torque levels as shown in **Table 1**. Fan bearings should be lubricated in accordance with the bearing manufacturer's recommendation and with the same type of grease. See lubrication chart page 18. The fan bearings are pre-lubricated at the factory. **The fan bearing cover should only be removed during inspection or maintenance, but only after the power to the motor has been turned off and locked out.** The bearing cover **must** be replaced before the power is turned back on.

V-Belt Drive

If Cincinnati Fan supplied the belts and sheaves (drives package), they were carefully selected for the specific operating conditions supplied to us by the customer.

⚠ Warning

Changing any of the V-belt drive component selections, supplied with the fan, could result in unsafe operating conditions which could cause equipment failure, personal injury and death.

If the user is supplying the sheaves and/or belts, it is their responsibility to make the correct component selections for the specific operating conditions. Their selection must also **not allow** the fan to exceed its maximum safe speed or hub load. If you do not know the maximum safe speed or hub load for this fan, **do not** make any drive selection without first consulting Cincinnati Fan or the sales office for your area. Timing belts should never be used on fans. If replacing belts and/or sheaves, checking belt tension or proper alignment, see **Figure 1** and **V-Belt Drive Installation**. Sheave set screws or taper-lock bushing bolts should be tightened to the torque values as indicated in **Table 1** and/or **Table 2**.

installation

V-Belt Drive Installation

Power to the motor must be turned off and locked out, Before inspecting, installing or servicing any components of the drives. Follow the following steps.

If installing new belts, inspect and replace any worn or damaged sheaves, bearings or shafts while the power is turned off and locked out. This will eliminate additional down time later to replace any other parts that were worn or defective.

If installing a complete set of new drives, the most critical steps of the installation are alignment of the sheaves and belt tension. **Misaligned sheaves and/or improper belt tension will cause excessive fan vibration and result in premature belt and /or bearing failure.**

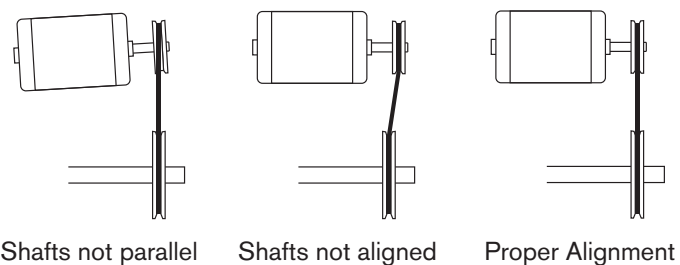

Figure 1

The fan and motor shafts must be parallel and the sheaves must be in-line with each other. See **Figure 1**.

Assembly Steps

The fan must be removed from the duct work or machine to install or replace the drives

1. Lockout and disconnect power to the motor.
2. Remove belt guard or belt guard/weather cover, if supplied.
3. Remove the screws that hold the bearing cover to the bearing base. Remove the cover.
4. The adjustable motor base should be used for belt tension adjustment. Loosen the tension on the belts by first loosening the four **locking bolts** in the side of the base, but **Do not** remove these bolts.
5. Turn the four **tensioning bolts** in the top of the motor base counter-clockwise, so the motor base moves as close to the fan drum as possible. This will reduce the tension on the belts.

Note



installation

6. Remove belt(s) from the motor sheave and then the fan sheave. Remove belt(s) from through the belt tube.

If replacing belts and sheaves, go on to Step 7. If replacing belts only, go to Step 12.

7. Loosen set screws or taper-lock bolts in the fan sheave and the motor sheave. Remove sheaves.
8. Check the fan and motor shafts for any nicks or burrs. Remove any burrs with a file or emery paper.
9. Slide new sheaves onto the fan and motor shafts. **Do not** drive or pound the sheaves on as this may damage the fan and/or motor bearings.
10. Align the fan and motor sheaves with a straight-edge (or string) as shown in **Figure 2**. If the sheaves are not the same width, align by sight. For more precise methods, consult your local drives dealer.

Note

Any sheave with a taper-lock bushing will slide a little on the shaft as the bolts are tightened. You will need to compensate for the sliding before performing Step 12.

If replacing the motor, you might need to adjust the motor on the motor base to keep the fan and motor shafts parallel as shown in Figure 1.

11. Slide the belt(s) into the belt tube and place the belt(s) over the sheaves. **Do not** force, pry or roll the belts, which could damage the cords in the belt(s). If there is more than one belt, all the belts should be a matched set.
12. After the sheaves are properly aligned and parallel, tighten the set screws and/or taper-lock hub bolts in the sheaves to the correct torque values shown in **Table 1** and/or **Table 2**.
13. Adjust the motor base, by turning the four tensioning bolts in the top of the base clockwise, until the belts appear to be snug, then recheck the alignment as in Step 10.
14. Finger tighten the locking bolts in the side of the base.

⚠ Caution

Before attempting the following steps, make sure the area around the fan is safe and secured so no one can get near the fan and get injured when it is started. Use caution and good judgment.

15. Reconnect or unlock power to the motor and run the fan for a few minutes to allow belts to seat properly. Then turn off and lock out the power to the motor.

installation

16. Loosen the four locking bolts in the side of the motor base, and re-adjust the belt tension using the four tensioning bolts in the top of the base.
17. Tighten the four locking bolts in the side of the motor base.
18. Unlock power to motor and run the fan. The belts should be running as shown in **Figure 3**. If not, repeat Step 10 through 14 after you have turned off power to the motor.
19. Disconnect power to the motor.
20. Reinstall the bearing cover and any safety guards.
21. Reinstall fan into the duct system or machine.
22. Reconnect power to the motor and turn on.
23. After running the fan for three days, lock out and disconnect power to the motor and remove fan from the duct system or machine.
24. Connect power to the motor and repeat Step 18.
25. Repeat any other steps as necessary.

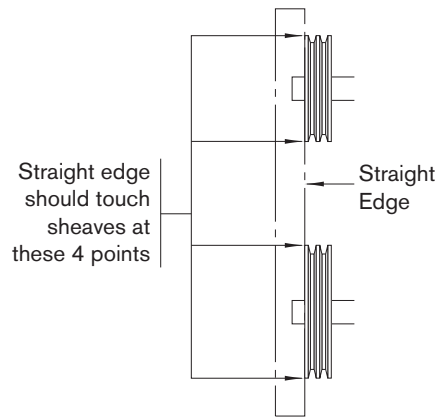

Figure 2

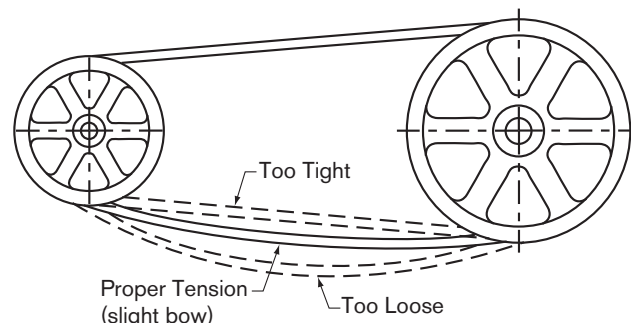

Figure 3

installation

Electrical

Disconnect Switches:

All fan motors should have an independent disconnect switch located in close visual proximity to turn off the electrical service to the fan motor. **Disconnects must be locked out in accordance with OSHA “lock out-tag out” procedures any time inspection or maintenance is being performed on the fan and/or motor assembly.** The “lock out-tag out” procedure should be performed by a licensed electrician or authorized personnel.

All disconnects should be sized in accordance with the latest NEC codes (National Electric Codes) and any local codes and should be installed only by a licensed electrician. “Slow blow” or “time delay” fuses or breakers should be used since the initial start-up time for the fan motor, although rare, can be up to 10 seconds.

Motor

All wiring connections, inspection and maintenance of any motor must be performed by a licensed electrician in accordance with the motor manufacturers recommendations, all electrical codes and OSHA regulations. Failure to properly install, make wiring connections, inspect or perform any maintenance to a motor can result in motor failure, property damage, explosion, electrical shock and death.

⚠ Warning

1. **Do Not connect or operate a motor without reading the motor manufacturers instructions supplied with the motor.** The basic principle of motor maintenance is: Keep the motor clean and dry. This requires periodic inspections of the motor. The frequency of the inspections depends on the type of motor, the service and environment it will be subjected to and the motor manufacturers instructions.
2. **Cleaning:** Cleaning should be limited to exterior surfaces only. Follow motor manufacturers cleaning instructions.
3. **Lubrication:** Most small motors have sealed bearings that are permanently lubricated for the life of the motor. Some larger motors have grease plugs that should be replaced with grease fittings to perform re-lubrication. These motors, or any motor with grease fittings, should be lubricated in accordance with the motor manufacturers recommendations. Lubrication frequency depends on the motor horsepower, speed and service. **Be sure** you use compatible grease and **Do not** over grease.

installation

4. **Location:** A standard Open Drip Proof or Totally Enclosed type motor is suitable in a clean, dry location below 104°F (40°C). If the location will be wet, dirty or reach temperatures above 104°F (40°C), a different type of motor may be necessary. Consult our local sales office for your area for proper motor selection assistance. All wiring must meet NEC (National Electric Codes) standards.
5. **Wiring Connections:** All wiring connections should be made for the proper voltage and phase as shown on the motor nameplate. Connections should follow the motor manufacturers recommendations as shown on the wiring schematic. This wiring diagram will be located on the outside of the motor, inside of the motor conduit box or on the motor nameplate. Reversing some wires might be necessary to get the correct fan rotation.
6. **Motors with Thermal Overload Protection:** If a motor is equipped with thermal overloads, the thermal overload must be wired per the wiring schematic to be operable. There are three types of thermal overloads:

Automatic: These will automatically shut the motor down if the internal temperature exceeds the design limits.

⚠ Caution

Make sure you lock out the power to the motor before inspecting any motor with automatic thermals, when the thermals cool down, they will allow the motor to automatically start up again, unless you have locked out the power to the motor.

Manual: These motors will have a button on them. If the motor overheats, it will shut down. After you have inspected the motor and eliminated the over-heating problem, you will need to “reset” it by pushing the button. Lock out the power Before inspecting the motor.

Thermostats: This type of thermal is a temperature sensing device **only**. If the motor overheats, the thermostats will open or close (depending on the type) and send a “signal” to the electrical box. **They will not turn the motor off.** These are pilot circuit devices that must be connected to the magnetic starter circuit.

7. **Explosion Proof Motors:** No motor is explosion proof. Explosion proof motors are designed so if there is an explosion **within** the motor, the explosion will be **contained inside** the motor and not allowed to get out to the atmosphere. All explosion proof motors must be selected based on the atmosphere and/or the environment the motor will be operating in. Explosion proof motors are designed, rated, and labeled for their operating conditions based on Classes, Groups and T Codes. The Class,



installation

Group and T Code of an EXP motor MUST be selected based on the atmosphere and/or environmental conditions the motor will be operating in. Consult the NEC (National Electric Code) and the NFPA (National Fire Protection Association) for the proper EXP motor Class, Group and T Code required for your specific application and location..

⚠ Warning

If an explosion proof motor is used in an area containing volatile liquids, gases, fumes or dust for which the motor was not designed to operate in, an explosion and/or fire may occur.

Note

All EXP motors have some type of thermal overload as required by UL (Underwriters Laboratories).

All EXP motors are required to have the UL and CSA (Canadian Standards Association) listing numbers on the motor name plate or on a separate plate attached to the motor. The Class, Group and T Code the motor is designed for must also be listed.

8. **Normal Motor Operating Temperatures:** The normal operating temperature of a fully loaded, open type, electric motor operating in a 70°F (21°C) ambient temperature is 174°F (79° C).

Maximum Fan Speed and Motor Speed Controllers:

If you will be using any type of motor speed controller with this fan, do not exceed the maximum safe fan speed. Installing and using a speed control device requires special training and certification as required by the speed control manufacturer. See the manufacturers instructions for proper use, installation and wiring connections for the maximum speed settings. It may be necessary to “block out” some speeds to eliminate a resonant vibration problem. The maximum safe fan speed is shown on the data sheet shipped with the fan. If you have lost the data sheet, contact Cincinnati Fan or the sales office for your area. You must have the serial number from the fan name plate for us to determine the maximum safe fan speed.

Cincinnati Fan will only extend the motor manufacturers warranty, when used with a speed controlling device, if the motor has the words **“Inverter Duty”** marked on the motor name plate. If the motor does not have “Inverter Duty” marked on the motor name plate, and you have a motor failure, you will be required to contact the motor manufacturer for any service or warranty claims.

operation

Pre-Startup and Post-Startup Check (Check blocks as each step is completed. Retain for you records)

Note

Failure to complete and document all the following Pre-Startup checks, Post-Startup checks and Vibration checks, could void all warranties.

Before mounting fan in duct work or on a machine:

If mounting this fan into a duct system with no access door in the fan drum, it is strongly recommended that an access door be installed in the duct work section next to the fan. That will allow access to perform the post-startup checks more easily.

Pre-Startup Check completed by: _____ Date _____

Eight Hour Post-Startup Check completed by: _____ Date _____

Three-Day Post-Startup Check completed by: _____ Date _____

Make sure power to the motor is locked out before starting pre-start or post-start checks.

- 1 Check the propeller by spinning it by hand to ensure it rotates freely.
- 2 Check the propeller set screws to make sure they are tight per **Table 1**.
- 3 If the propeller has a taper-lock bushing, make sure the bolts are tightened per **Table 2**.
- 4 Make certain there is no foreign material in the fan or duct work that can become a projectile.
- 5 Ensure all electrical power components are properly sized and matched for your electrical system.
- 6 Record the Full Load Amps listed on the motor nameplate. You will need to refer to this later

Low Voltage Amps: _____

High Voltage Amps: _____

After Mounting Fan in Duct Work or On a Machine

- 7 Check all duct work hardware to make sure it is tight.
- 8 Make sure any inspection doors in the duct work are securely bolted or locked.
- 9 Check that any required guards are properly secured.
- 10 Any dampers or valves should be fully opened and closed to make sure there is no binding or interference.
- 11 If your fan is mounted on an elevated support structure, make sure the structure is welded at all the joint connections and the structure is properly braced to prevent any "side sway".
- 12 Make sure the propeller is stationary prior to startup. **Starting a fan with a propeller that is rotating backwards can cause propeller damage.**
- 13 Make the necessary wiring connections to the motor per National Electric Code (NEC) regulations.



operation

Pre-Startup Check completed by: _____ Date _____
Eight Hour Post-Startup Check completed by: _____ Date _____
Three-Day Post-Startup Check completed by: _____ Date _____

- 14 Apply power to the motor momentarily (i.e. bump start) to check for propeller fan rotation. If the fan is rotating in the wrong direction, reconnect the motor leads per the motor manufacturers wiring schematic. The fan rotation must match the rotation indicated by the rotation arrow decals on the outside of the fan drum. After reconnecting the leads, repeat this step.
- 15 Apply power to the fan motor and let it come up to full speed. Turn off the power. Listen for any unusual noise or mechanical abnormality while the propeller is still spinning. If any are noticed, lock out the power, wait for the propeller to come to a complete stop, locate the cause and correct it.
- 16 Unlock power and start the fan.
- 17 Measure, record and keep the following motor data for future reference and comparison:
(Single phase motors will only have L1 and L2 leads)
Amperage draw on each motor lead: L1 _____ L2 _____ L3 _____
(Running amps **should not** exceed the motor name plate amps for the voltage being operated on).
Compare these amp readings to the Full Load Amps you recorded in Step 6.
Voltage coming to motor leads: L1 _____ L2 _____ L3 _____
(Should be about the same input voltage on all leads)

Vibration

All propellers are balanced to comply with ANSI S2.19, G6.3. However, rough handling in shipment and/or erection, weak and/or non-rigid foundations, and misalignment may cause a vibration problem after installation. After installation, the vibration levels should be checked by personnel experienced with vibration analysis and equipment.

maintenance

Routine Inspection and Maintenance

Periodic inspection of all the fan parts is the key to good maintenance and trouble-free operation. The frequency of inspections must be determined by the user and is dependent upon the severity of the application. **But**, it should **never** exceed a 12 month period. The user should prepare an inspection and maintenance schedule and make sure it is adhered to.

⚠ Caution

Before starting any inspection or maintenance, be sure fan is turned off, power is locked out and the propeller has been carefully secured to prevent wind milling. If the operating conditions of the fan are to be changed (speed, pressure, temperature, etc.) consult Cincinnati Fan or our sales office in your territory to determine if the unit will operate safely at the new conditions.

Hardware

All fan hardware should be checked to make sure it is tight. All set screws or taper-lock bushing bolts should be tightened to the torque values shown in **Tables 2 and 3**.

Note

If any set screws have become loose, they must be replaced. Never use set screws more than once. Replace with knurled, cup-point set screws with a nylon locking patch.

Motor and Fan Bearing Lubrication

Most smaller motors have sealed bearings that never require relubrication for the life of the motor. For any motors with grease fittings, consult the motor manufacturers recommendations with reference to the lubrication frequency and the type of grease that should be used.

Do not over grease the motor bearings. Generally, 1-2 shots should be enough. Use a hand operated grease gun at no more than 40 psi. If possible, **carefully** lubricate the motor bearings while the motor is running.

Fan Bearings

The fan bearings should be re-lubricated per the chart on page 18 and also located on the outside of the fan drum. Use this chart for all clean and dry applications where the fan airstream temperature is -20°F (-29°C) up to 200°F (93°C). This would be the correct temperature limits for Model TAF and WAF fans. Although the airstream temperature can be up to 200°F (93°C), the fan bearings (inside the bearing cover) will only be subjected to a maximum of 120°F (49°C).



maintenance

For HTF and HTF/WAF model fans, the maximum airstream temperature limit is 375°F (191°C). A chart similar to the chart below will also specify that only Dow Corning DC-44 high temperature (silicone based) grease should be used.

Do not overgrease the fan bearings. Generally, 1-2 shots should be enough. Use a hand-operated grease gun at no more than 40 PSI. **If possible, carefully lubricate the fan bearings while the fan is running.**

Fan Bearings are Pre-Lubricated and Ready for Use Recommended Lubrication Frequency in Months						
Fan Operating Speed RPM	Fan Shaft Diameter (OD)					
	1/2" to 1"	1 1/8" to 1 1/2"	1 5/8" to 1 15/16"	2" to 2 1/2"	2 11/16" to 3 3/16"	3 7/16" to 3 15/16"
Up to 500	6	6	6	6	5	5
500 - 1000	6	6	6	5	4	4
1000 - 1500	6	5	5	4	3	2
1500 - 2000	5	5	4	3	2	1
2000 - 2500	5	5	3	2	2	
2500 - 3000	5	4	2	2	1	
3000 - 3500	4	3	2	1		
3500 - 4000	3	3	1			
4000 - 4500	2	2	1			
4500 - 5000	2	1				

The above lubrication frequencies are based on the fan bearings operating in a clean and dry environment from -20°F (-29°C) up to 120°F (49°C). For hostile, moisture laden environments and/or temperatures below -20°F (-29°C) or above 120°F (49°C), consult the bearing manufacturer for the proper grease type and recommended lubrication frequencies.

If possible, carefully lubricate the bearings while the fan is running.

Add grease until a slight bead appears at the bearing seals. **Do not** over grease.

Generally, 1-2 shots with a hand grease gun that has a maximum pressure rating of 40 psi. **Over greasing bearings will cause them to run hot.**

The type of grease you use **must be** compatible with the grease already in the bearings.

maintenance

Propeller Balancing

All propellers are balanced at the factory. It is not uncommon that additional “trim balancing” is required after the fan is assembled. Trim balancing of the fan assembly, in the field, is typically always necessary for all replacement propellers.

Airstream material or chemicals can cause abrasion or corrosion of fan parts. This wear is generally uneven and, over time, will lead to the propeller becoming unbalanced causing excessive vibration. When that happens, the propeller must be rebalanced or replaced. The other airstream components should also be inspected for wear or structural damage and cleaned or replaced if necessary. **After cleaning any propeller, it should be balanced.**

There are two ways to balance a propeller:

Add balancing weights for fabricated aluminum, steel or stainless steel propellers:

Balance weights should be rigidly attached to the propeller at a location that will not interfere with the fan housing nor disrupt air flow. They should (if at all possible) be welded to the propeller. When trim balancing the propeller, on the fan shaft, be sure to ground the welder directly to the propeller. Otherwise, the welding current will likely pass through the fan shaft and damage the fan and/or motor bearings.

Grinding off material for cast aluminum propellers:

When grinding on the propeller to remove material, be very careful not to grind too much in one area. That could affect the structural integrity of the propeller.

Vibration

As mentioned previously in this manual, excessive vibration can cause premature motor and/or fan bearing failure that could lead to catastrophic failure of the fan. After performing any routine maintenance, vibration readings should be taken. New readings should be taken (maximum every 12 months) and compared to the readings previously recorded. If any major differences are present, the cause should be determined and corrected before the fan is put back into operation.

The most common causes of vibration problems are:

- Propeller unbalance
- Bearing Failure
- Foundation stiffness
- Mechanical looseness
- Misaligned sheaves and/or belts
- Poor fan inlet and/or discharge conditions

maintenance

Fan Shaft and Bearing Replacement

The fan shaft and bearings for Cincinnati Fan tube axial fans are carefully selected to match the maximum load and operating conditions. If the instructions in this manual and those provided by the bearing manufacturer are followed, you should not need to replace the bearings for many years.

When the bearings need to be replaced, the fan shaft should also be replaced.

Use the following applicable steps when replacing the fan shaft/bearing assembly:

1. **Lock out the power source and disconnect the power at the motor conduit box.**
2. Remove the entire fan/motor assembly from the duct work or machine.
3. Place fan on the floor or on a work bench, with the motor on top, and secure the fan so it cannot roll.
4. Measure and record the distance from the end of the fan shaft to the front of the propeller hub.
5. Loosen and remove the two set screws in the propeller. They will have to be replaced.
6. Pull the propeller off of the fan shaft being careful not to deform the blades.
7. Loosen (do not remove) the four locking bolts in the side of the motor adjustment base.
8. Turn (do not remove) the four tensioning bolts in the top of the motor adjustment base counter-clockwise to loosen the tension on the belt(s).
9. **TAF and HTF models only:** Remove the screws in the bearing cover and remove cover. On HTF models, be careful when removing the cover so as not to tear the insulation fabric inside and underneath the cover. Proceed to Step 12.
9. **WAF and WAF/HTF models only:** Remove the caulking on the front of the moisture displacement collar and remove the set screw in the collar that holds the collar on the fan shaft.
10. **WAF and WAF/HTF models only:** Remove the four screws holding the cover over the fan shaft onto the bearing cover.
11. **WAF and WAF/HTF models only:** Carefully remove the bearing cover so as not to damage the gasket under the cover on WAF models, or the insulation fabric inside and underneath the cover on WAF/HTF models. Proceed to Step 12.

maintenance

12. Slide the belt(s) off of the motor sheave and then the fan sheave.
13. Remove the belt(s) through the top of the belt tube.
14. Loosen the set screws, or the bolts in the taper-lock bushing, of the fan sheave and remove the sheave from the fan shaft.

Note

It should not be necessary to loosen or remove the motor sheave..

15. Disconnect the grease fittings from the bearings being careful not to kink the grease lines.
16. Remove the bolts that hold the bearings onto the bearing base.
17. Remove the fan shaft and bearings as an assembly.
18. Measure and record the distance from both ends of the fan shaft to the bearings on each end.
19. Dispose of the old shaft and bearings.
20. Install the new fan bearings onto the bearing base with the hardware removed in Step 16. **Do not** tighten at this time. Be sure the bearing locking collars are facing each other and the set screws are in line with each other. **On HTF and WAF/HTF models, there is an insulation fabric that covers the entire bearing mounting plate surface.** The bearings are mounted on top of this fabric.
21. Install the new fan shaft into the bearings so it extends out from both bearings per the dimensions recorded in Step 18. Be sure the bearing locking collars are facing each other and the set screws are in line with each other.
22. Tighten the bearing mounting bolts that hold the bearings to the bearing base.
23. Using a soft-faced mallet, **gently** tap on the shaft in between the two bearings while turning the shaft by hand. This will seat the bearing races. The shaft must turn freely.
24. Tighten the set screws in both bearings to the proper torque values shown in **Table 1**. If there are two set screws per bearing, make sure you tighten one set screw of one bearing in line with one set screw in the other bearing, then tighten the other two set screws.
25. Turn the fan shaft by hand again to make sure it turns freely and does not bind.
26. Carefully re-install the lubrication fittings into the bearings.
27. Install a new key into the keyway of the fan shaft for the fan sheave.



maintenance

28. Replace the set screws in the fan sheave or the bolts in the fan sheave, taper-lock bushing.
29. Re-install the fan sheave onto the fan shaft and check the fan sheave alignment with the motor sheave. Both sheaves must be aligned as shown in **Figure 2**.
30. After you have properly aligned the fan and motor sheaves, lock the set screws or the taper-lock bushing bolts in the fan sheave to the torque values shown in **Table 1** or **Table 2**.
31. Re-install the belt(s) onto the fan and motor sheaves.
32. Adjust the tension on the belt(s) by turning the four adjustment bolts on the top of the motor base. To obtain proper belt tension, refer to the **V-Belt Installation** section.
33. **TAF and HTF models only:** Re-install the bearing cover over the bearings, install the bolts and tighten them. On **HTF** models, the insulation fabric **must** still be in place inside the bearing cover and on the bearing base surface where the bearings are mounted. Proceed to Step 37.
33. **WAF models only:** Check the gasket on the bearing base, where the bearing cover will be mounted, to assure it is in good condition. If not, it **must** be replaced. Re-install the bearing cover over the bearings, install the bolts and tighten them.
34. **WAF models only:** Re-apply a small bead of silicone caulk on the back surface of the cover that you removed in Step 10. Slide the cover over the fan shaft and mount it on the front of the bearing cover with the four screws.
35. **WAF models only:** Replace the set screw in the moisture displacement collar and then slide the collar over the fan shaft until it just clears the front of the bearing cover. Turn the fan shaft, by hand, to make sure the collar is not rubbing on the bearing cover.
36. **WAF models only:** Tighten the set screw in the collar onto the fan shaft to the appropriate torque value in Table 1 on page 4. Apply a bead of silicone caulk around the shaft on the front of the collar. Proceed to Step 37.
33. **WAF/HTF models only:** Check to make sure the insulation fabric inside the bearing cover, and on the bearing base, is in good condition. If not, it **must** be replaced. Re-install the bearing cover over the bearings, install the bolts and tighten them.

maintenance

34. **WAF/HTF models only:** Re-apply a small bead of silicone caulk on the back surface of the cover that you removed in Step 10. Slide the cover over the fan shaft and mount it on the front of the bearing cover with the four screws.
35. **WAF/HTF models only:** Replace the set screw in the moisture displacement collar and then slide the collar over the fan shaft until it just clears the front of the bearing cover. Turn the fan shaft, by hand, to make sure the collar is not rubbing on the bearing cover.
36. **WAF/HTF models only:** Tighten the set screw in the collar onto the fan shaft to the appropriate torque value in **Table 1**. Apply a bead of silicone caulk around the shaft on the front of the collar. Proceed to Step 37.
37. Install new set screws in the propeller.
38. Install a new key in the fan shaft keyway for the propeller.
39. Install the propeller onto the fan shaft and locate the hub on the shaft to the same dimension recorded in Step 4.
40. Carefully spin the propeller, by hand, and listen for any rubbing or grinding sounds. If any are heard, find the cause and make the necessary corrections.
41. Tighten the propeller set screws onto the fan shaft to the appropriate torque value in **Table 1**. **Tighten the set screw over the key first and then tighten the set screw onto the shaft.**
42. Repeat Step 40.
43. Re-install the fan into your duct work or onto your machine.
44. Reconnect the electrical wires to the motor.
45. Bump start the motor and then turn it off. Check the fan rotation as it slows down. If necessary, make wiring changes to correct the fan rotation. This step should only be necessary on 3 Phase motors.
46. After running the fan for three days, lock out and disconnect power to the motor and remove fan from the duct system or machine.
47. .Repeat Step 7 and then Steps 34, 43, 44 and 45.

Dampers and Shutters: (airflow control device)

Turn off and lock out power to the fan motor. Any dampers or shutters should be periodically inspected to make sure all parts are still operable within their full range and there is no interference with any other damper or fan components. Any bearings or seals should be checked for their proper function. The manufacturers maintenance instructions should be followed.

maintenance

Safety Equipment and Accessories

It is the user's responsibility to make sure that any safety guards required by company, local, state and OSHA regulations are properly attached and fully functional at all times. If any guards become defective or non-functional at any time, the power to the fan **must** be turned off and locked-out until complete repairs and/or replacements have been made, installed and inspected by authorized personnel. Any accessories used in conjunction with the fan should also be inspected to make sure they are functioning within their intended limits and design specifications. The manufacturer's maintenance manuals should be referred to for correct maintenance procedures. These accessories include, but are not limited to, the following:

- Shaft seals, inspection doors, vibration isolators or vibration bases, air flow or pressure measuring equipment, hoods, controls, special coatings, silencers, expansion joints, valves, flexible connectors, filters, sheaves and belts.

Replacement Parts

Under normal conditions, you should not need any spare or replacement parts for at least 24 months after shipment from Cincinnati Fan. That does not include any wear due to abrasion, corrosion, excessive temperatures, abuse, misuse, accident or any severe conditions the fan was not designed for.

- If this fan is vital to any process that could cost you lost revenue, we strongly recommend that you keep a fan propeller and motor at your location.
- If this fan is vital for the safety of any people and/or animals, we strongly recommend that you keep a complete fan/motor assembly, as originally ordered, at your location.

To order parts or complete units, contact us for the name of our sales office in your area or locate them on our website at **cincinnati.com**.

Note

The fan serial number from the fan name plate is required to identify parts correctly.

maintenance

Troubleshooting

Potential problems and causes listed below are in no order of importance or priority. The causes are only a list of the most common items to check to correct a problem. If you find the cause of a problem, **do not** assume it is the **only** cause of that problem. Different problems can have the same causes.

 **Warning**

Troubleshooting should only be performed by trained personnel. Any potential electrical problems should only be checked by a licensed electrician. All safety rules, regulations and procedures must be followed.

Trouble	Cause
Excessive Vibration	Loose mounting bolts, set screws or taper-lock hub bolts
	Misalignment motor shaft and fan shaft
	Worn or corroded propeller
	Accumulation of foreign material on propeller
	Bent motor or fan shaft
	Worn motor and/or fan bearings
	Motor out of balance
	Inadequate structural support
	Support structure not sufficiently cross braced
Airflow (CFM) Too Low	Weak or resonant foundation
	Propeller turning in wrong direction (rotation)
	Actual system static pressure (SP) is higher than expected
	Motor speed or fan speed too low
	Damper or shutter not adjusted properly
	Leaks or obstructions in duct work
	Filters dirty
	Inlet and/or discharge guards are clogged
	Duct elbow too close to fan inlet and/or discharge
Airflow (CFM) Too High	Improperly designed duct work
	Actual system static pressure (SP) is lower than expected
	Motor or fan speed (RPM) too high
	Filter not in place
Motor Overheating	Damper or shutter not adjusted properly
	Actual system static pressure (SP) is lower than expected
	Voltage supplied to motor is too high or too low
	Motor speed (RPM) too high or defective motor
	Air density higher than expected
	Motor wired incorrectly and/or loose wiring connections
Note – a normal motor will operate at 174°F	



maintenance

Excessive Noise	Propeller rubbing inside of housing
	Worn or corroded propeller
	Accumulation of foreign material on propeller
	Loose mounting bolts, set screws or taper-lock hub bolts
	Bent motor shaft or fan shaft
	Worn motor and/or fan bearings
	Motor out of balance
	Motor and/or fan bearings need lubrication
	Vibration originating elsewhere in system
	System resonance or pulsation
	Inadequate or faulty design of fan support structure
Fan operating near stall condition due to incorrect system design or installation	
Fan Doesn't Operate	Motor wired incorrectly or loose wiring connections
	Incorrect voltage supply
	Defective fuses or circuit breakers
	Power turned of elsewhere
Defective motor	

Long Term Storage

Storage exceeding 30 days after receipt of equipment.

Failure to adhere to these instructions voids all warranties in their entirety.

Note

- Storage site selection:
 - Level, well-drained, firm surface, in clean, dry and warm location. Minimum temperature of 50°F (10°C).
 - Isolated from possibility of physical damage from construction vehicles, erection equipment, etc.
 - Accessible for periodical inspection and maintenance.
- The fan should be supported under each corner of its base to allow it to “breathe”. Supports (2 x 4s, timbers, or railroad ties) should be placed diagonally under each corner.
- If the equipment is to be stored for more than three (3) months, the entire fan assembly must be loosely covered with plastic, **but not tightly wrapped**.
- Initial inspections must be made of the fan components, and immediate corrective action taken if discrepancies are found, to insure adequate protection of the equipment during storage.
 - Sheave center distance should be reduced to reduce tension on the belts.

maintenance

- Storage Maintenance:

Note

A periodic inspection and maintenance log, by date and action taken, must be developed and maintained for each fan. See example below. Each item must be checked monthly.

Storage/Maintenance Schedule Log Example	
Action	Date Checked
Reinspect units to insure any protective devices used are functioning properly. Check for scratches in the finish which will allow corrosion or rust to form	
Rotate propeller a minimum of 10 full revolutions to keep the moor bearing grease from separating and drying. This is a critical step.	

- General Motor Procedure:

If the motor is not put into service immediately, the motor must be stored in a clean, dry, warm location. Minimum temperature of 50°F. (10°C,). Several precautionary steps must be performed to avoid motor damage during storage.

- Use a “Megger” each month to ensure that integrity of the winding insulation has been maintained. Record the Megger readings. Immediately investigate any significant drop in insulation resistance.
- **Do not** lubricate the motor bearings during storage. Motor bearings are packed with grease at the factory. Excessive grease can damage the insulation quality in the motor.
- If the storage location is damp or humid, the motor windings must be protected from moisture. This can be done by applying power to the motor’s space heaters, (if available) while the motor is in storage. If the motor does not have space heaters, storing it in a damp or humid location will, very quickly, cause internal corrosion and motor failure which is not warranted.
- Rotate motor shaft a minimum of 10 full turns each month to keep bearing grease from separating and drying out.

Note

For specific storage instructions, for the actual motor and any accessory parts that were supplied, refer to the manufacturer’s instructions.

information

Limited Warranty

Cincinnati Fan and Ventilator Company (Seller) warrants products of its own manufacture, against defects of material and workman-ship under normal use and service for a period of eighteen (18) months from date of shipment or twelve (12) months from date of installation, whichever occurs first. This warranty does not apply to any of Seller's products or any part thereof which has been subject to extraordinary wear and tear, improper installation, accident, abuse, misuse, overloading, negligence or alteration. This warranty does not cover systems or materials not of Seller's manufacture. On products furnished by Seller, but manufactured by others, such as motors, Seller extends the same warranty as Seller received from the manufacturer thereof. Expenses incurred by Purchaser's in repairing or replacing any defective product will not be allowed except where authorized in writing and signed by an officer of the Seller.

The obligation of the Seller under this warranty shall be limited to repairing or replacing F.O.B. the Seller's plant, or allowing credit at Seller's option.

This warranty is expressly in lieu of all other warranties either expressed or implied including the warranties of merchantability and fitness for a particular purpose and of all other obligations and liabilities of the seller. The purchaser acknowledges that no other representations were made to purchaser or relied upon by purchaser with respect to the quality or function of the products herein sold.

Removal of the Sellers nameplate or any generic fan nameplate containing the fan serial number voids all warranties, either writ-ten or implied. Failure to complete and document all the pre-startup and post startup checks and perform the suggested routine maintenance checks voids all warranties, either written or implied.

information

Limitation of Liability

Notice of any claim, including a claim for defect in material or workmanship, must be given to Seller in writing within 30 days after receipt of the equipment or other products. Seller reserves the right to inspect any alleged defect at Purchaser's facility before any claim can be allowed and before adjustment, credit, allowance replacement or return will be authorized. See RETURNS below. Seller's liability with respect to such defects will be limited to the replacement, free of charge, of parts returned at Purchaser's expense F.O.B. Seller's plant and found to be defective by the Seller.

In no event will seller be liable for special, indirect, incidental or consequential damages, whether in contract, tort, negligence, strict liability or otherwise, including without limitation damages for injury to persons or property, lost profits or revenue, lost sales or loss of use of any product sold hereunder. Purchaser's sole and exclusive remedy against seller will be the replacement of defective parts as provided herein or refund of the purchase price for defective products, at seller's sole option. Seller's liability on any claim, whether in contract, tort, negligence, strict liability or otherwise, for any loss or damage arising out of or in connection with purchaser's order or the products or equipment purchased hereunder, shall in no case exceed the purchase price of the equipment giving rise to the claim.

Responsibly

It is the understanding of the Seller that Purchaser and/or User will use this equipment in conjunction with additional equipment or accessories to comply with all Federal, State and local regulations. The Seller assumes no responsibility for the Purchaser's and/or User's compliance with any Federal, State and local regulations.

Returns

Cincinnati Fan & Ventilator Company assumes no responsibility for any material returned to our plant without our permission. An RMA (Return Material Authorization) number must be obtained and clearly shown on the outside of the carton or crate and on a packing slip. Any items returned must be shipped freight prepaid. Failure to comply will result in refusal of the shipment at our receiving department.

information

Disclaimer

This manual, and all its content herein, is based on all applicable known material at the time this manual was created. **Any parts of this manual are subject to change at any time and without notice.**

If any statements, diagrams and/or instructions contained herein, for components not manufactured by the Seller, conflict with instructions in the manufacturer's manual (i.e.: motors, bearings, dampers, etc.), the instructions in the manufacturer's manual, for that component take precedent.

Should you want the latest version of this manual, please contact us or our sales office for your area. Or, you can print a current version by going to our website at: cincinnati-fan.com.

Parts Drawing

Cincinnati Fan manufactures many models and arrangements with special variations. For that reason, the maintenance manuals contained on our website do not include a parts drawing nor the completed blower or fan specifications on page 2.

For the parts drawing of all the standard components and specifications for the specific blower or fan that you have, please contact our local Cincinnati Fan sales office for your area.

You will need to give them the serial number shown on the blower or fan nameplate so they can supply you the correct information.

Click on "Contact a Sales Rep" on our website for the name and contact information for our local sales office in your area.

Axial Fan

USER MANUAL

SPX ENGINEERED AIR MOVEMENT

7697 SNIDER ROAD

MASON, OH 45040 USA

513 573 1000 | [spxairmovement.com](https://www.spxairmovement.com)

CF-15-IOM-24 | ISSUED 5/2024

©2024 SPX ENGINEERED AIR MOVEMENT | ALL RIGHTS RESERVED

In the interest of technological progress, all products are subject to design and/or material change without notice.

SPX 
TECHNOLOGIES